

Improving Object Storage Performance

10 Gigabit Intel® Ethernet Converged Network Adapter and Intel® Solid-State Drives boost throughput capacity of TEAMSUN's object storage solution



"10 Gigabit Intel® Ethernet Converged Network Adapters have helped the TEAMSUN Openstack Swift object storage solution increase the data throughput capacity by more than five times and concurrent access amount by over four times. Using Intel® Solid-State Drives for the metadata storage improved overall performance by 20 percent."¹

Zheng Chi
Product Manager
Beijing TEAMSUN Technology Co., Ltd

With the rapid development of the Internet and cloud computing, the amount of unstructured data—such as text, images, audio and video—has exploded at an exponential rate. This has the marketplace turning to highly scalable object storage solutions to meet growing data demands. Realizing the need for improvement, Beijing TEAMSUN Co., Ltd. (TEAMSUN), China's leading IT integrated services provider, worked with Intel to carry out testing and performance optimization of its Openstack* Swift* object storage solution running on Intel® architecture.

CHALLENGES

- **Enhance core competitiveness.** Provide clients a with a highly scalable storage solution to improve TEAMSUN's competitiveness in the marketplace.
- **Improve utilization rate of storage resources.** Improve the load balancing and data throughput capacity of proxy servers so the object storage solution can fully use its storage node's maximum data input/output capacity.
- **Optimize performance.** Improve write performance of the metadata in the Openstack Swift object storage solution.

SOLUTIONS

- **Utilize 10 Gigabit Intel® Ethernet Converged Network Adapter.** Adopt 10 Gigabit Intel Ethernet Converged Network Adapter X520-DA2 to remove network bottleneck.
- **Utilize Intel® Solid-State Drives (Intel® SSDs).** Use Intel SSDs to store the accounts and container data information of the Openstack Swift object storage solution.

IMPACT

- **Improved utilization of storage resources.** 10 Gigabit Intel Ethernet Converged Network Adapter X520-DA2 helped TEAMSUN's Openstack Swift object storage solution increase its data throughput capacity by more than five times and the concurrent connection by more than four times. The data read/write capacity and resources of the storage nodes can now be fully utilized.¹
- **Improved overall performance.** Using Intel SSDs for metadata storage helped TEAMSUN improve its Openstack Swift object storage solution's overall performance by more than 20 percent.¹

Improving data storage scalability

TEAMSUN's businesses have covered almost all the fields of IT services, including cloud computing, mobile Internet, Internet of Things, and information security. Through these services, TEAMSUN aims to provide its customers with appropriate data storage solutions.

"In the past years, services such as micro-blogging, online games, online video, and enterprise private cloud have grown at an explosive rate. All these applications have generated vast amounts of unstructured data, like text, images, audio, video, and virtual machine mirror images. These static files need to be stored for a long time. They are mainly retrieved for read requests, and are unlikely to be updated or deleted very frequently. This poses increasingly severe challenges in terms of capacity expansion and data service performance for the traditional vertical storage solution," shared Zheng Chi, product manager for TEAMSUN.

TEAMSUN evaluated the performance of Openstack Swift-based object storage solution on Intel® architecture, using Cloud Object Storage Benchmark (COSBench), which is an open source benchmark tool for Cloud Object Storage Services.

¹ All performance tests were performed and are being reported by Beijing TEAMSUN Co.Ltd. Please contact TEAMSUN for more information on any performance test reported here.

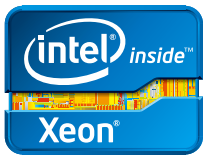

10 Gigabit Intel® Ethernet Converged Network Adapter and Intel® SSDs have improved the overall performance of the TEAMSUN object storage solution

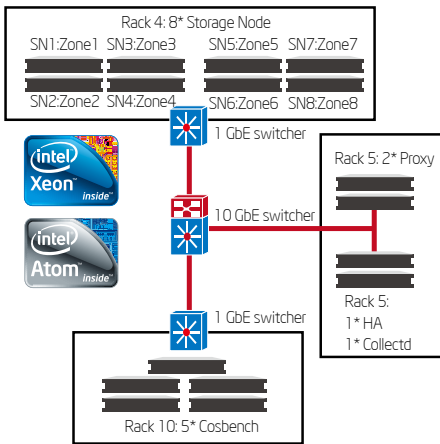

Figure 1. Initial test environment at TEAMSUN

The test solution consisted of one load-balancing server, two proxy servers, and eight storage nodes. Another server was used to collect the test data. Five more servers were used as the stress test clients. Each of these servers included Intel® Xeon® processors E5 2680, 64GB of memory, and a SATA mechanical hard drive with 2TB capacity.

Ethernet data throughput capacity hinders storage resources utilization

In the first phase of testing, the Intel® Ethernet Server Adapter I350, designed for Gigabit Ethernet, was used in all servers. The file size was between 50KB and 200KB; the distributions of data write, read, and deletion were 5 percent, 90 percent, and 5 percent, respectively; and five pressure test client ends were allowed to operate continuously for 30 minutes.

Where there are 100 concurrent connections from the test clients, the load balancing server already attained a network throughput of 817Mbps, close to the theoretical maximum network throughput. The service throughput of the test system was at 827 operations per second (OPS). When the concurrent connections were increased to 2,000, the service throughput was only increased slightly to 830 OPS. However, the average service response time had grown significantly from 500ms to over 2 seconds. The utilization rate of the processors, memory and network in all

storage nodes remained very low. The data throughput capacity of the load balancing server adapter caused a bottleneck in the storage node utilization.

Boosting data throughput capacity

TEAMSUN then replaced the Intel Ethernet Server Adapter I350 in the load balancing server and proxy server with 10 Gigabit Intel Ethernet Converged Network Adapter X520-DA2, while the test method and procedures remained unchanged.

The test results showed that the increased bandwidth delivered significant performance improvements. With 300 concurrent connections, the five pressure test client ends attained a total bandwidth of 4.2Gbps, close to the maximum combined theoretical bandwidth. The Ethernet flow of the eight storage nodes stood at about 600Mbps, while the network utilization of the load balancing and the proxy server was only about 25 percent. The service throughput of the test system was at 4100 OPS. When the concurrent connections was increased to 2,000, the service throughput of the whole system increased to 4,500 OPS. The average service response time remained below 500ms.

“The two test results showed that when using 10 Gigabit Intel Ethernet Converged Network Adapter X520 in the load balancing server and proxy server, the service throughput can be increased by more than five times and the concurrent connections supported increased by four times,” explained Zheng. “In our actual solution, the performance can be improved further, because the processors, memory, and bandwidth of the load balancing and proxy server have not been fully utilized. With the same configuration, we continued to simulate other commonly seen application scenarios, such as online video, enterprise backup, virtual machine mirror image, files with a size of between 10MB and several gigabytes. All the test results showed that the 10 Gigabit Intel Ethernet Converged Network Adapter X520-DA2 has offered us satisfactory performance.”

Optimized metadata storage and improved overall performance

In the Openstack Swift-based object storage solution, new files are written into the data container when it already contained many

LESSONS LEARNED

- 10 Gigabit Intel® Ethernet Converged Network Adapter has higher data throughput capacity, helping the Openstack Swift object storage solution at TEAMSUN achieve the storage node's maximum data read/write capability and increase concurrent connections.
- Intel® SSDs have excellent data write capacity. When used for the metadata storage of the intensive data exchange in the laterally expanding storage solution, it can significantly improve the system's overall performance.

object files. The performance of the whole system is affected, since time is needed to update the metadata.

To test the benefit of using SSD, TEAMSUN setup one proxy server and two stress test client ends, while the storage structure remained unchanged. The test procedure was:

- Write 100,000 object files in four containers in advance
- Write a file of 64KB with 2048 concurrent connections

The test results showed that, with mechanical hard drive, the system's service throughput was about 3,500 operations per second, and the data average response time was about 580ms. TEAMSUN then switched to use Intel SSD 320 in each storage node for the metadata storage (i.e, account and container information). The service throughput grew to 4,200 operations per second, with the data average response time reduced to 480ms. The TEAMSUN Openstack Swift object storage solution has improved overall performance by 20 percent.¹

As a result of the tests, TEAMSUN is adopting both 10 Gigabit Intel Ethernet Converged Network Adapter X520 series and Intel SSDs into its Openstack Swift-based object storage solution. Now TEAMSUN is beginning testing and validation of Intel's latest datacenter SSD product, the Intel SSD DC S3500, which offers more consistent performance and reliability features. TEAMSUN will continue to cooperate with Intel in developing industry solutions, particularly in the fields of storage, data center optimization, and transferring open source technology into products, to promote the development of the industry and the application of new technology.

Find a solution that's right for your organization. Contact your Intel representative, visit Intel's Business Success Stories for IT Managers (www.intel.com/itcasestudies) or explore the Intel.com IT Center (www.intel.com/itcenter).

This document and the information given are for the convenience of Intel's customer base and are provided "AS IS" WITH NO WARRANTIES WHATSOEVER, EXPRESS OR IMPLIED, INCLUDING ANY IMPLIED WARRANTY OF MERCHANTABILITY, FITNESS FOR A PARTICULAR PURPOSE, AND NON-INFRINGEMENT OF INTELLECTUAL PROPERTY RIGHTS. Receipt or possession of this document does not grant any license to any of the intellectual property described, displayed, or contained herein. Intel® products are not intended for use in medical, lifesaving, life-sustaining, critical control, or safety systems, or in nuclear facility applications.

Software and workloads used in performance tests may have been optimized for performance only on Intel microprocessors. Performance tests, such as SYSmark and MobileMark, are measured using specific computer systems, components, software, operations and functions. Any change to any of those factors may cause the results to vary. You should consult other information and performance tests to assist you in fully evaluating your contemplated purchases, including the performance of that product when combined with other products.

¹All performance tests were performed and are being reported by Beijing TEAMSUN Co.Ltd. Please contact TEAMSUN for more information on any performance test reported here.

© 2013, Intel Corporation. All rights reserved. Intel and the Intel logo are trademarks of Intel Corporation in the U.S. and other countries.

*Other names and brands may be claimed as the property of others.